



CIVA

Intermediate

Programme4

DONAC 2018

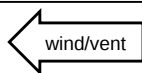

R

Figure K

231

Total K

261

Judges Name		Flight #
Signature	Number	

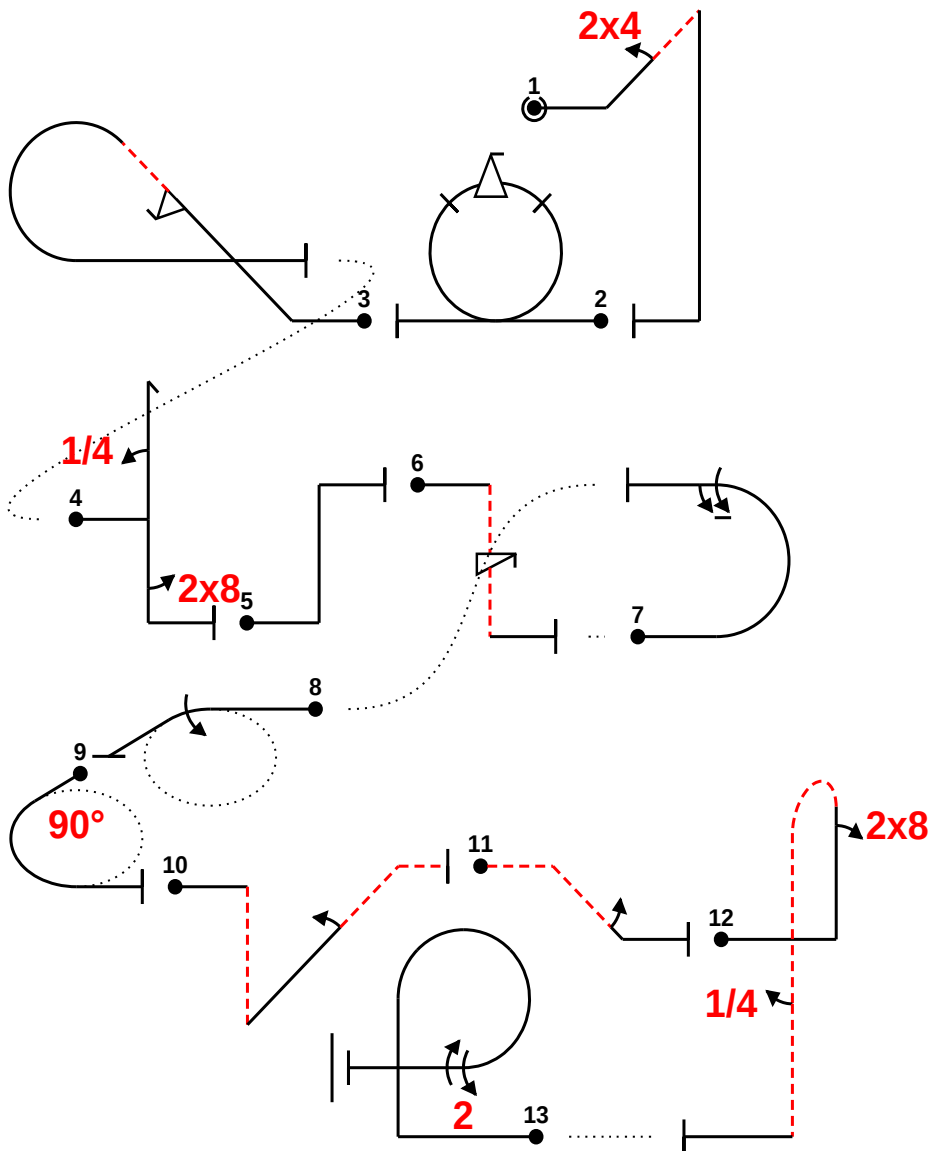

Fig	Pos	Remarks	Grade
1			.
2			.
3			.
4			.
5			.
6			.
7			.
8			.
9			.
10			.
11			.
12			.
13			.

.	Harmony 0	Positioning 30	.
---	--------------	-------------------	---

Too Low		Trg Violation	
Too High		Wing Rocks	
Interruptions		Disqual Fig	
Insertions		Other(note...)	

Fig 1 C	K	Fig 2 B	K	Fig 3 D	K	Fig 4 F	K	Fig 5 L	K	Fig 6 H	K	Fig 7 E	K	Fig 8 I	K	Fig 9 L	K	Fig 10 J	K	Fig 11 L	K	Fig 12 G	K	Fig 13 A	K
1.2.3.1	12	7.4.1.1	10	8.5.2.1	10	5.2.1.1	17	1.1.6.1	10	1.1.6.3	10	7.2.2.1	6	2.1.3.1	14	2.1.1.1	3	1.2.8.3	15	1.1.3.4	7	8.4.3.1	15	8.6.1.1	11
9.4.2.2	7	9.9.3.4	11	9.9.2.2	13	9.1.1.1	6			9.1.1.4	5	9.1.3.6	10					9.1.2.2	6	9.1.4.2	4	9.8.1.1	7	9.2.3.4	9
	19		21		23	9.8.5.1	3		8		15		16		14		8		21		8	9.1.5.1	2	9.1.3.4	8
							26															24			28

Pilot:

A/C:



CIVA

Intermediate

Programme4

DONAC 2018

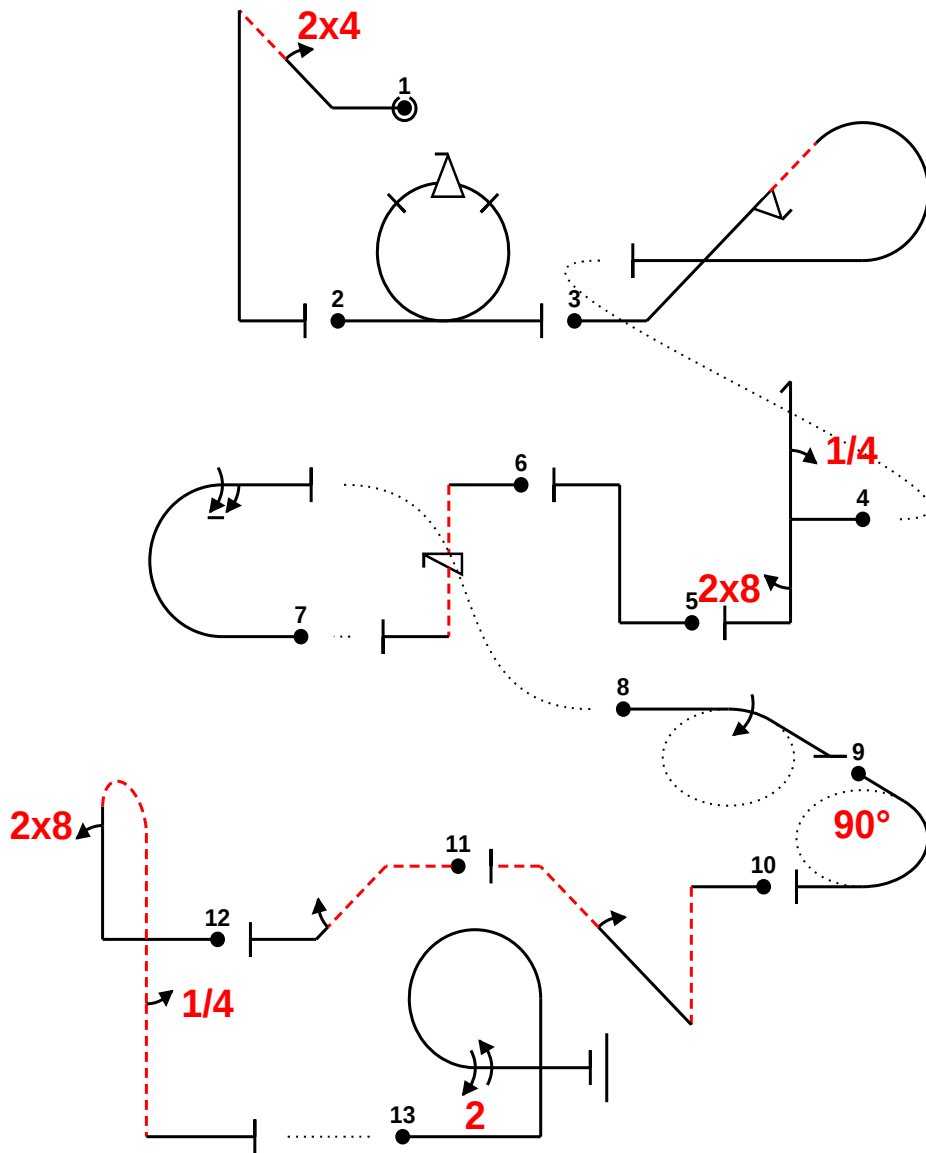

Figure K

231

Total K

261

Judges Name

Flight #

Signature

Number

Fig	Pos	Remarks	Grade
1			.
2			.
3			.
4			.
5			.
6			.
7			.
8			.
9			.
10			.
11			.
12			.
13			.

.	Harmony 0	Positioning 30	.
---	--------------	-------------------	---

Too Low		Trg Violation	
Too High		Wing Rocks	
Interruptions		Disqual Fig	
Insertions		Other(note...)	

Fig 1 C	K	Fig 2 B	K	Fig 3 D	K	Fig 4 F	K	Fig 5 L	K	Fig 6 H	K	Fig 7 E	K	Fig 8 I	K	Fig 9 L	K	Fig 10 J	K	Fig 11 L	K	Fig 12 G	K	Fig 13 A	K
1.2.3.1	12	7.4.1.1	10	8.5.2.1	10	5.2.1.1	17	1.1.6.1	10	1.1.6.3	10	7.2.2.1	6	2.1.3.1	14	2.1.1.1	3	1.2.8.3	15	1.1.3.4	7	8.4.3.1	15	8.6.1.1	11
9.4.2.2	7	9.9.3.4	11	9.9.2.2	13	9.1.1.1	6			9.1.1.4	5	9.1.3.6	10					9.1.2.2	6	9.1.4.2	4	9.8.1.1	7	9.2.3.4	9
	19		21		23	9.8.5.1	3		8		15		16		14		8		21		8	9.1.5.1	2	9.1.3.4	8
							26													8		24			28

Pilot:

A/C:

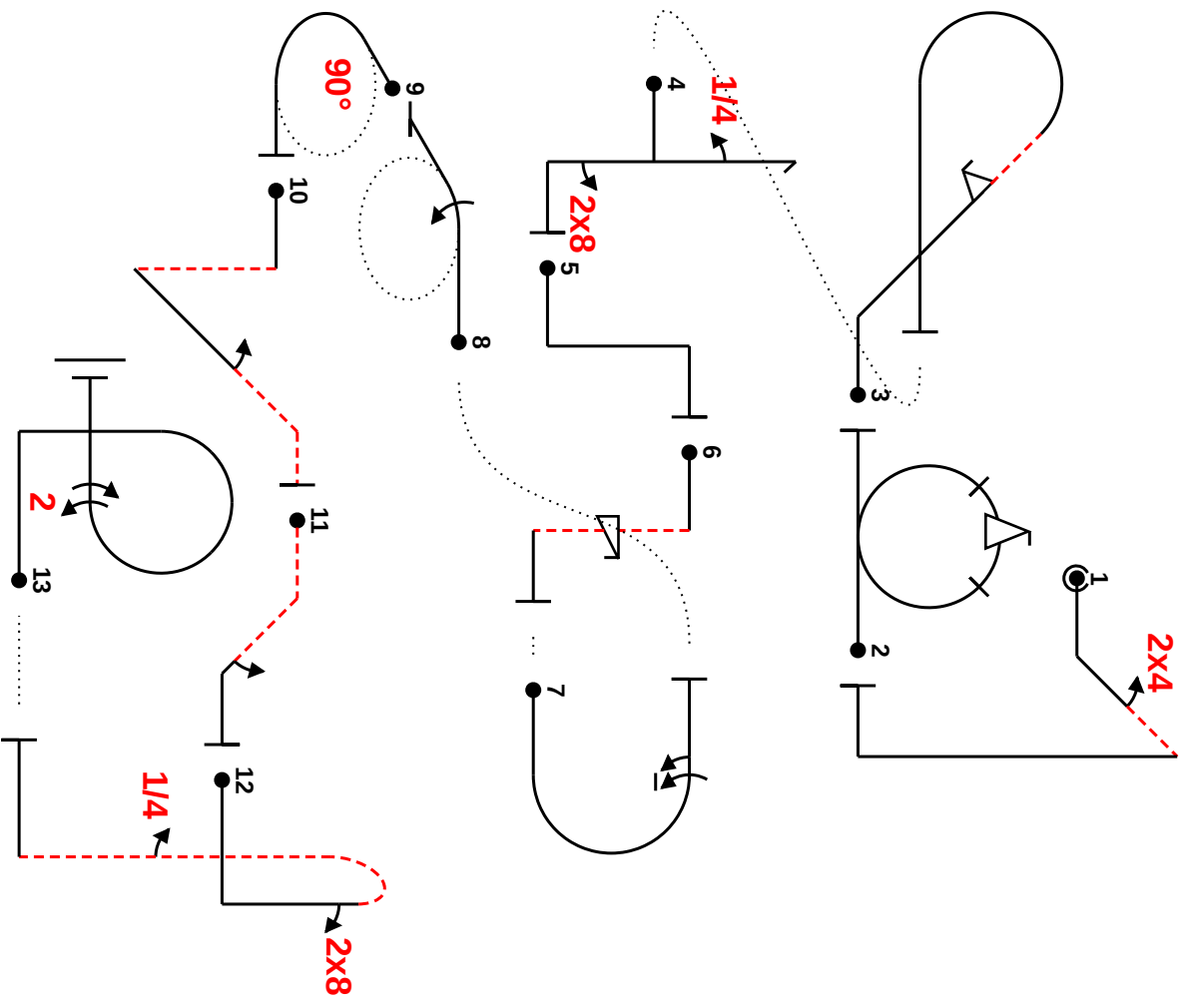

wind/vent

wind/vent

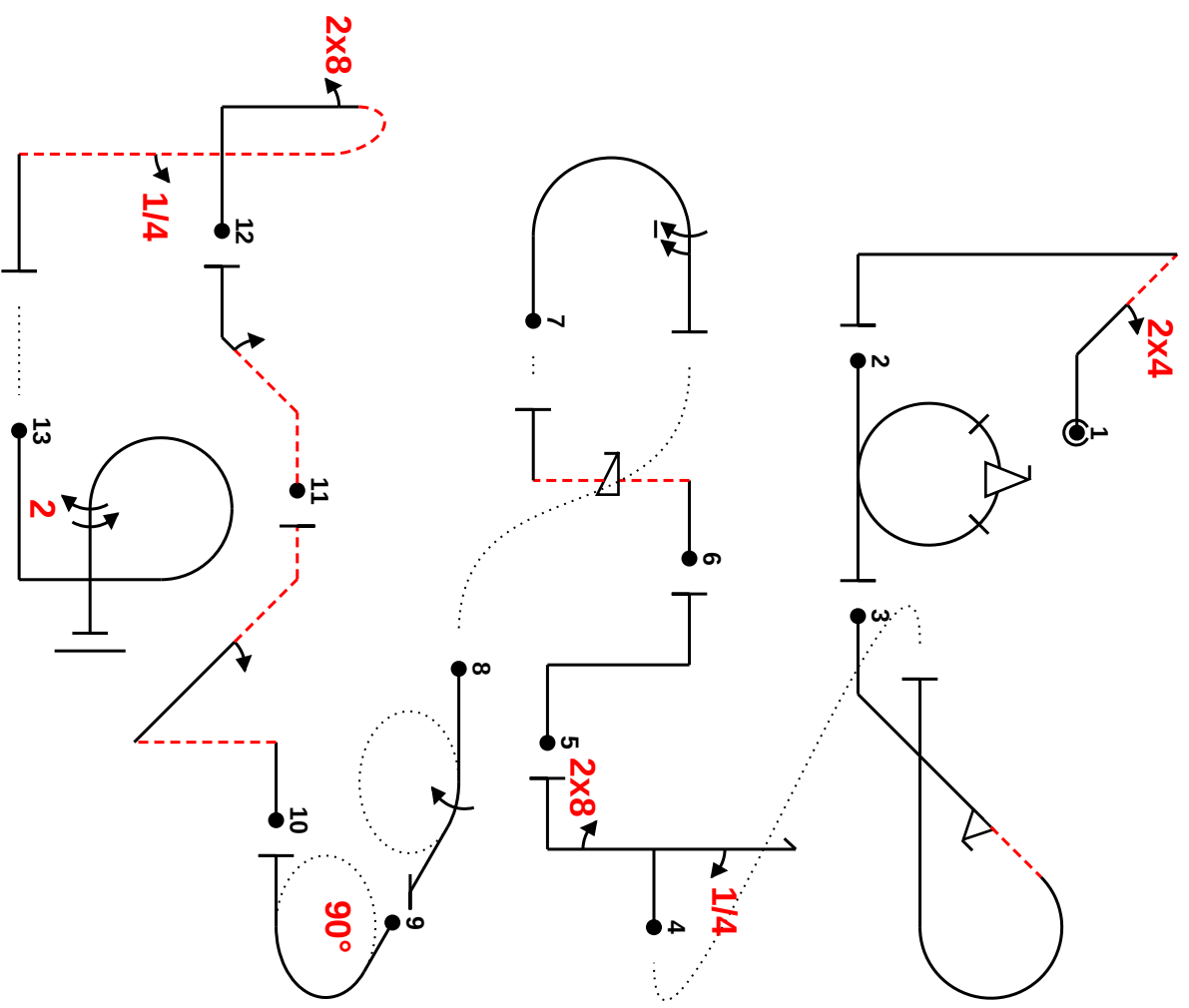

wind/vent

wind/vent