



CIVA Intermediate

Unknown2

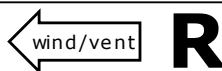

Figure K  
217

Total K  
247

Judges Name	
Signature	Number

Flight #
----------

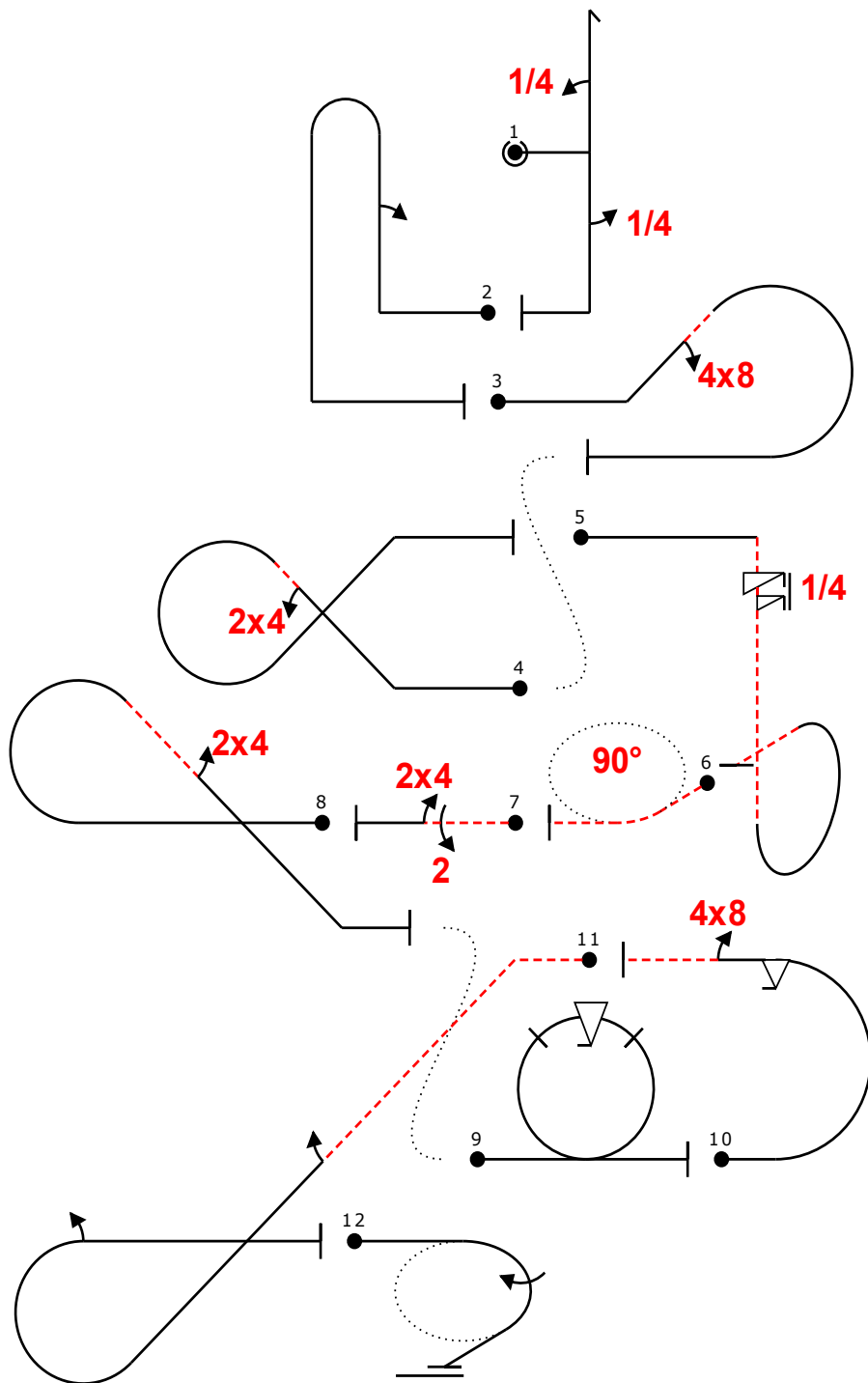

Fig	Pos	Remarks	Grade
1			.
2			.
3			.
4			.
5			.
6			.
7			.
8			.
9			.
10			.
11			.
12			.

Positioning	30	.
-------------	----	---

Too Low		Box Outs	
Too High		Missed Slot	
Interruptions		Wing Rocks	
Insertions		Disqualified	

"@A" 4h4. "@B" ,2''b.'''+ 2% "@C" ~~~~~,48''rc.....+ (0,13) "@D" +24g+ "@E" " 2> ++5s...irp- "@L" -j- "@F" -22,24 "@G" c.24. (0,13) "@H" of 4% "@I" ``+m2f,48- "@L" -...2.... irc2 "@J" ljl

Fig 1 A	K	Fig 2 B	K	Fig 3 C	K	Fig 4 D	K	Fig 5 E	K	Fig 6 L	K	Fig 7 F	K	Fig 8 G	K	Fig 9 H	K	Fig 10 I	K	Fig 11 L	K	Fig 12 J	K
5.2.1.1	17	8.4.1.1	13	8.5.2.1	10	7.3.2.1	14	8.6.3.3	13	2.1.1.2	4	1.1.1.4	2	8.5.6.1	10	7.4.1.1	10	7.2.1.1	6	8.5.4.4	11	2.1.3.1	14
9.1.1.1	6	9.1.1.2	8	9.8.2.2	9	9.4.2.2	7	9.1.1.5	4			9.2.3.4	9	9.4.4.2	5	9.9.3.4	11	9.9.3.2	11	9.1.4.2	4		
9.1.5.1	2											9.4.3.2	5					9.8.3.2	7	9.1.3.2	4		
	25		21		19		21		17		12		16		15		21		24		12		14

Pilot:

A/C:



CIVA Intermediate

Unknown2

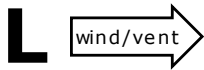

Figure K

217

Total K

247

Judges Name	
Signature	Number

Flight #
----------

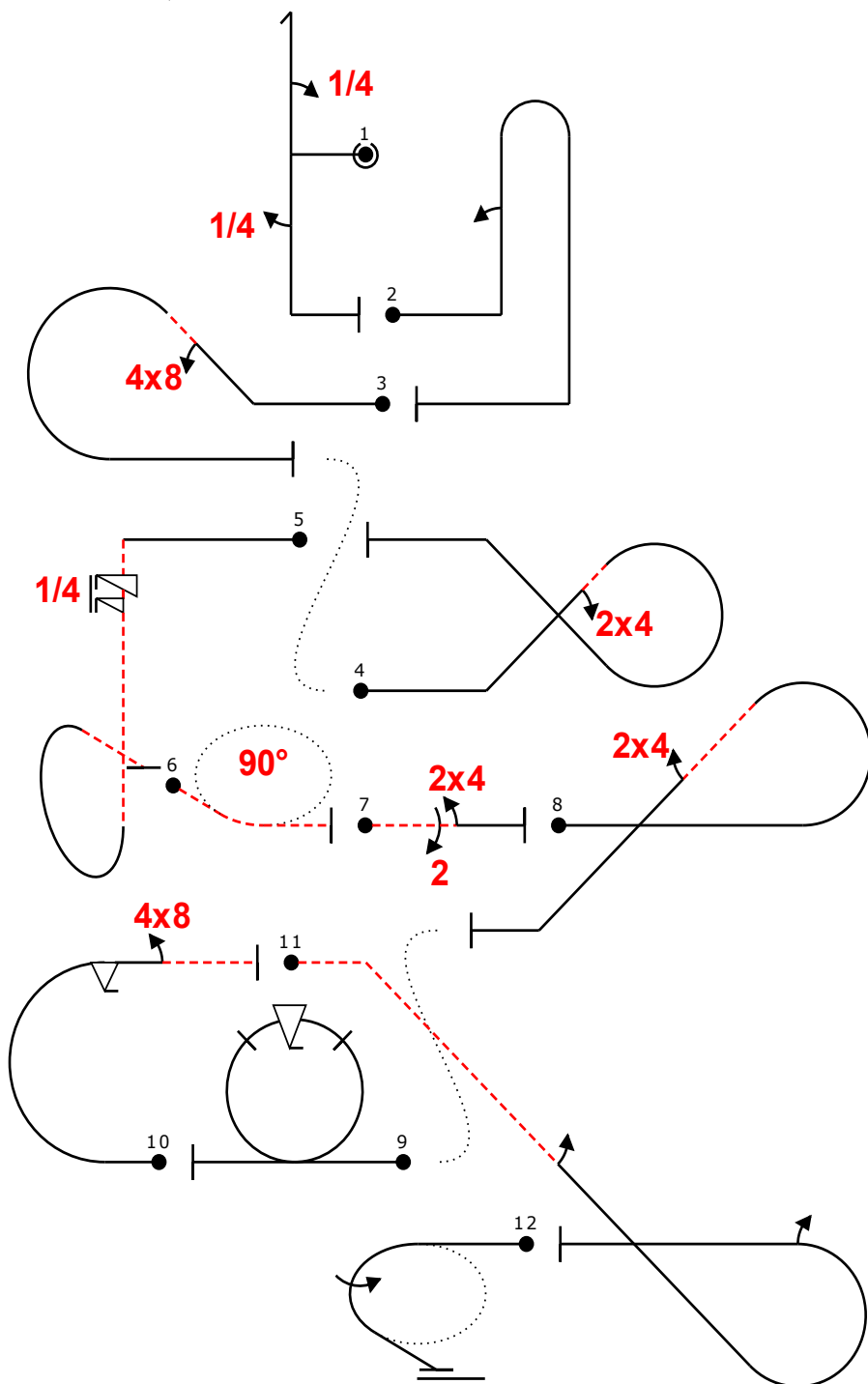

Fig	Pos	Remarks	Grade
1			.
2			.
3			.
4			.
5			.
6			.
7			.
8			.
9			.
10			.
11			.
12			.

Positioning	30	.
-------------	----	---

Too Low		Box Outs	
Too High		Missed Slot	
Interruptions		Wing Rocks	
Insertions		Disqualified	

"@A" 4h4. "@B" ,2''b.'''+ 2% "@C" ~~~~~,48''rc.....+ (0,13) "@D" +24g+ "@E" " 2> ++5s...irp- "@L" -j- "@F" -22,24 "@G" c.24. (0,13) "@H" of 4% "@I" ~~~+m2f,48- "@L" -...2.... irc2 "@J" ljl

Fig 1 A	K	Fig 2 B	K	Fig 3 C	K	Fig 4 D	K	Fig 5 E	K	Fig 6 L	K	Fig 7 F	K	Fig 8 G	K	Fig 9 H	K	Fig 10 I	K	Fig 11 L	K	Fig 12 J	K
5.2.1.1	17	8.4.1.1	13	8.5.2.1	10	7.3.2.1	14	8.6.3.3	13	2.1.1.2	4	1.1.1.4	2	8.5.6.1	10	7.4.1.1	10	7.2.1.1	6	8.5.4.4	11	2.1.3.1	14
9.1.1.1	6	9.1.1.2	8	9.8.2.2	9	9.4.2.2	7	9.1.1.1.5	4			9.2.3.4	9	9.4.4.2	5	9.9.3.4	11	9.9.3.2	11	9.1.4.2	4		
9.1.5.1	2											9.4.3.2	5					9.8.3.2	7	9.1.3.2	4		
	25		21		19		21		17		12		16		15		21		24		12		14

Pilot:

A/C: