



Pilot ID

Flight #

Intermediate Programme Known

No	Symbol	Cat. No.	K	Total K	Marks	Remarks	Pos	Item	K	Grade
1		8.6.2.1 9.1.1.1 9.1.3.1 9.1.3.3	12 6 2 6	26				Pos.	30	
2		8.5.1.2 9.1.3.2 9.1.3.6	10 4 10	24				Fig K		Total K
								179		209
								Penalties		
3		1.3.12.1 9.4.4.2	21 5	26				Too Low		
								Disqual Fig		
								Too High		
								Outs		
4		1.1.6.3 9.11.1.5	10 4	14				Interruptions		
								Insertions		
								Missed Slot		
								Trg Violation		
								Faulty Wing Rocks		
5		8.4.1.1 9.1.5.1	13 2	15				Final Freestyle		
								Duration	Min	Sec
6		7.4.1.1 9.9.3.4	10 11	21				Judges Details		
								Signature		
								Name		
7		5.2.1.1	17	17				Number		
8		7.2.2.1 9.4.3.4 9.4.3.2	6 11 5	22						
9		2.1.3.1	14	14						

Pilot

A/C



Pilot ID

Flight #

Intermediate Programme Known

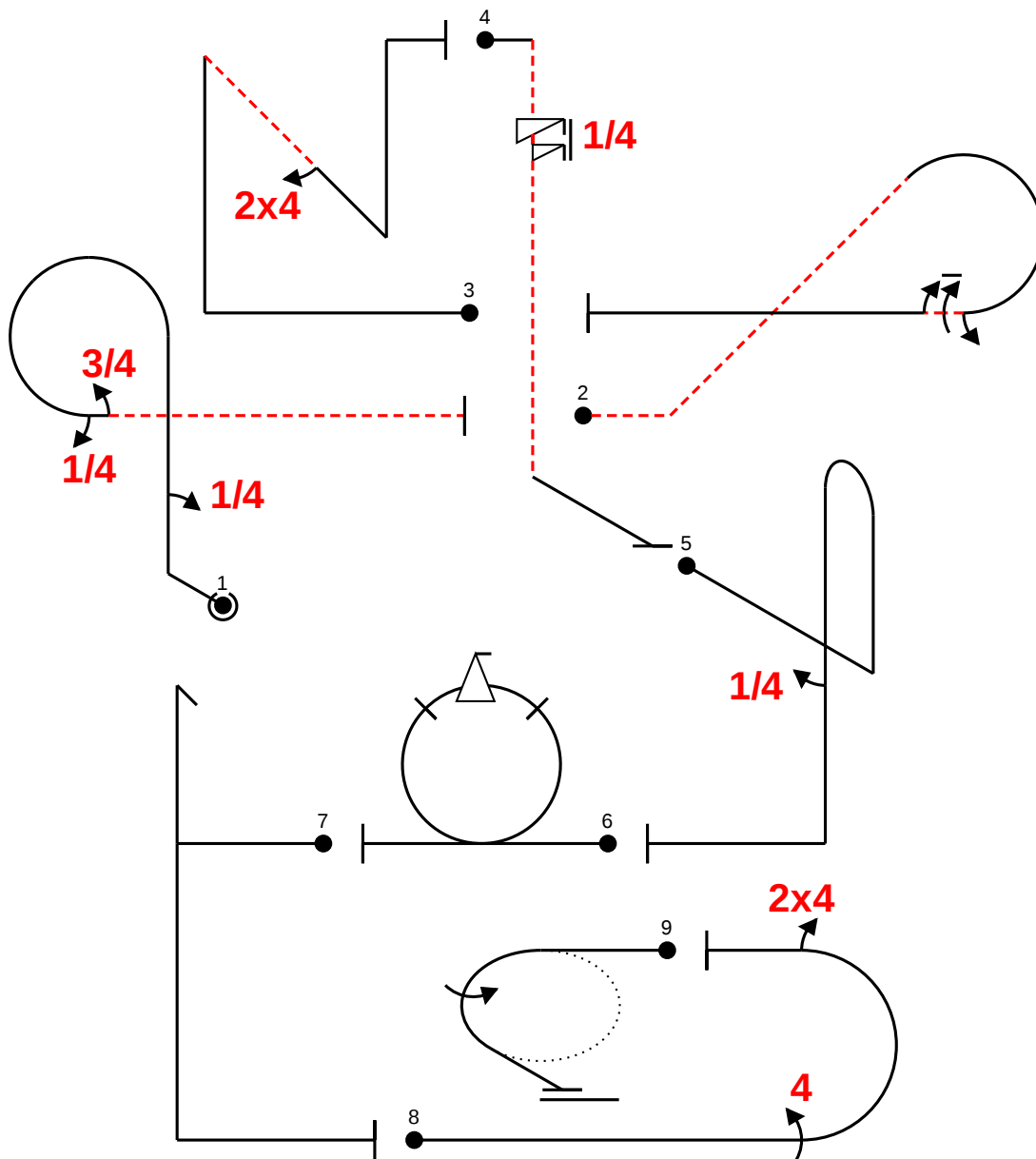
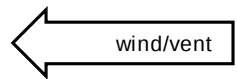

Power			
Fig 1	8.6.2.1	12	26
	9.1.1.1	6	
	9.1.3.1	2	
	9.1.3.3	6	
Fig 2	8.5.1.2	10	24
	9.1.3.2	4	
	9.1.3.6	10	
Fig 3	1.3.12.1	21	26
	9.4.4.2	5	
Fig 4	1.1.6.3	10	14
	9.11.1.5	4	
Fig 5	8.4.1.1	13	15
	9.1.5.1	2	
Fig 6	7.4.1.1	10	21
	9.9.3.4	11	
Fig 7	5.2.1.1	17	17
	7.2.2.1	6	
	9.4.3.4	11	
Fig 8	9.4.3.2	5	22
	2.1.3.1	14	
	14	14	
Total K = 179			

 Pilot
 A/C



Pilot ID

Flight #

Intermediate Programme Known

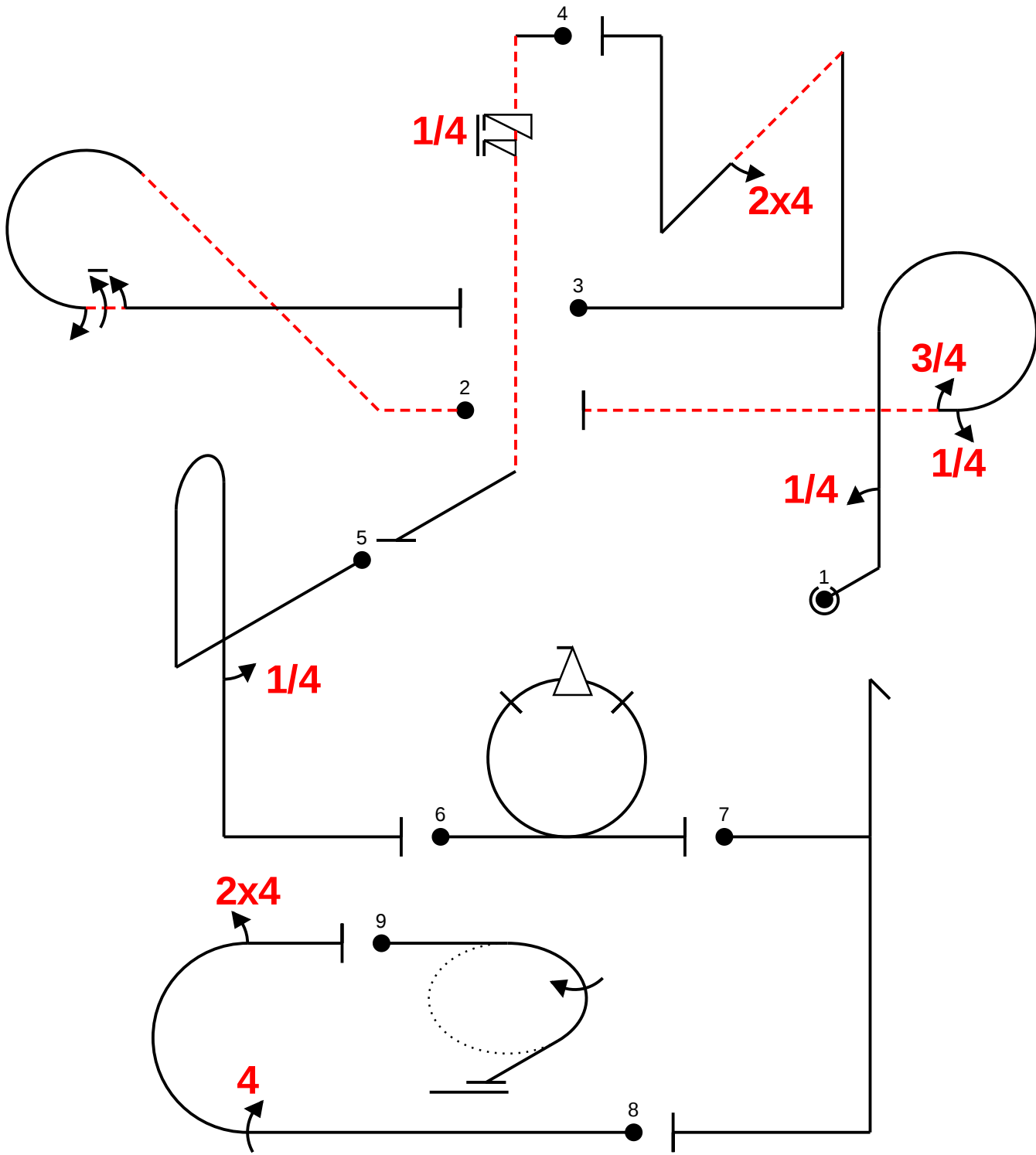
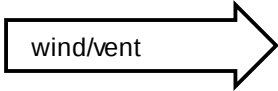

Pilot
A/C