

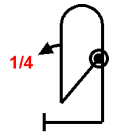
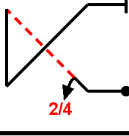
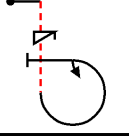
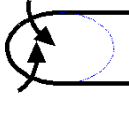
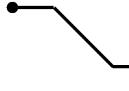
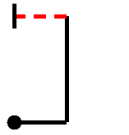

Pilot ID #

Flight #

No	Symbol	Catalog No	K	Tot K	Score	Remarks
1		8.1.1 9.1.1.1	13 6	19		
2		1.29.1 9.4.2.2	18 7	25		
3		8.40.3 9.11.1.4 9.1.3.2	13 5 4	22		
4		2.6.1	13	13		
5		1.2.3	7	7		
6		1.7.1	9	9		
7		1.1.2 9.1.3.4	3 8	11		
8		1.7.4	9	9		
9		5.1.1 9.1.1.2 9.1.5.1	17 8 2	27		
10		7.1.1	6	6		
11		2.1.4	7	7		

Item	K	Score
Positioning		
PENALTIES	Interruptions	
	Insertions	
	Too high	
	Too low	
	Outs	
	Other	
Disqual Fig #		
T/O time		
End time		

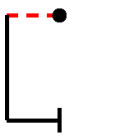
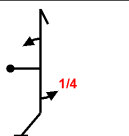
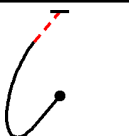
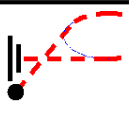
Fig K	Total K
155	

Judges Details
Signature
Name
Number

pilot

A/C

FORM B

Pilot ID #

Flight #

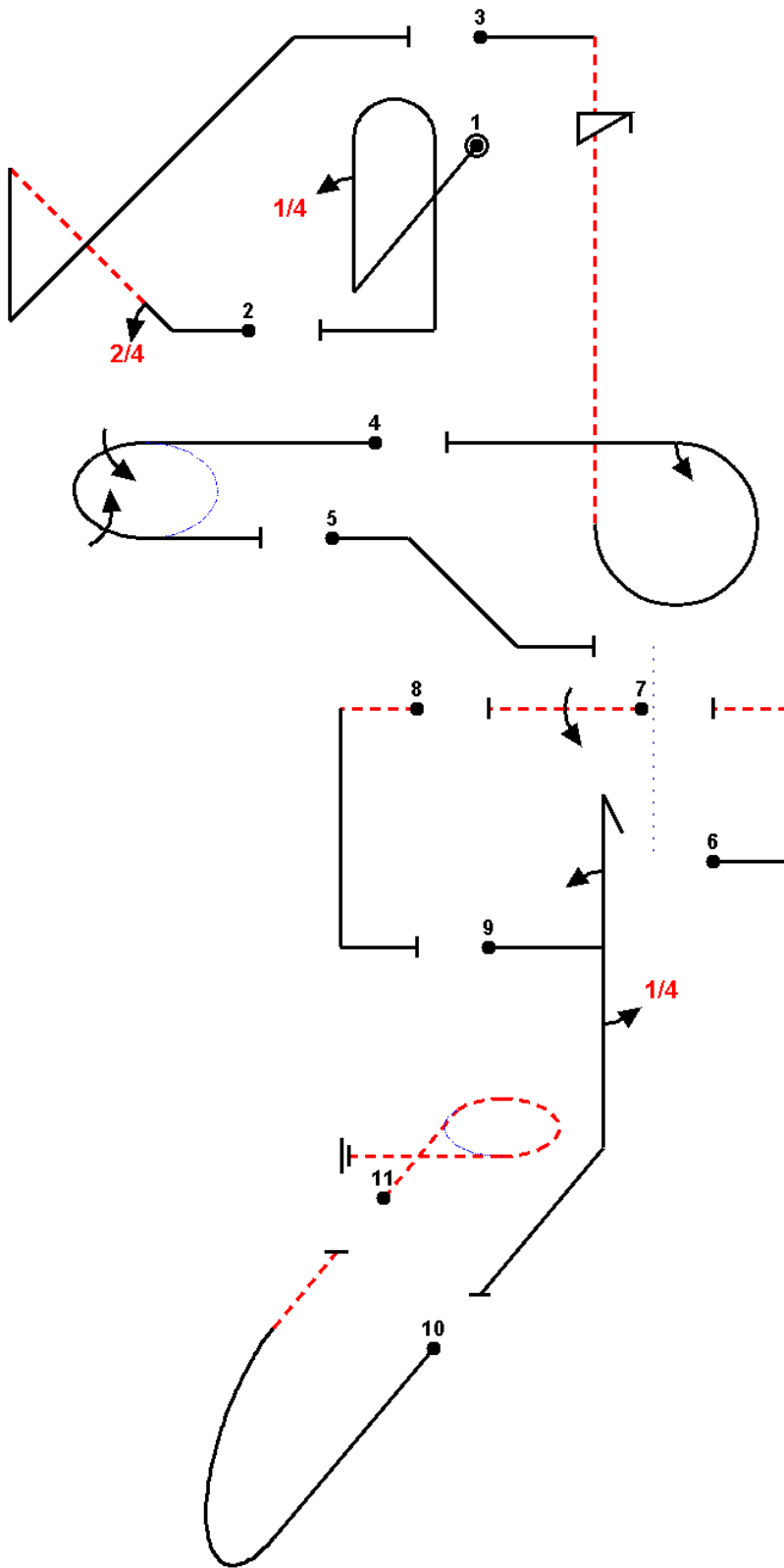

Total K = 155 (6k@10,27k@9)

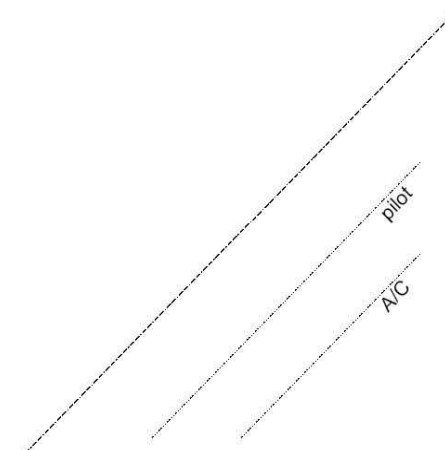

FORM C

Pilot ID #

Flight #

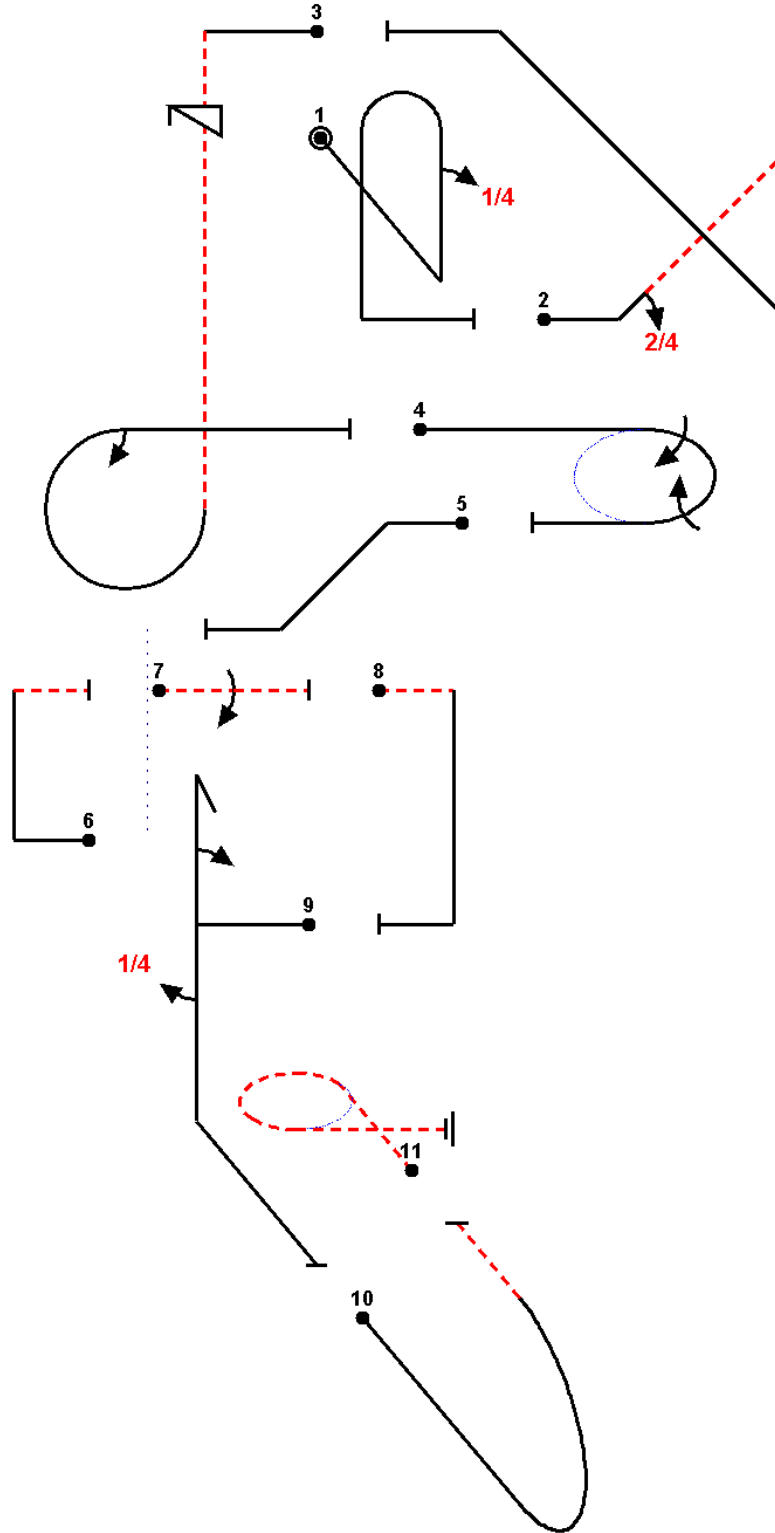

Total K = 155 (6k@10,27k@9)

No Verification information available for this sequence type: ...

 Pilot

 A/C